



OEM – 2

Universal sound system interface and controller

The OEM-2 may be used in any one of four possible configurations and system types.

- 1) Replacing a premium factory radio with an aftermarket stereo and use the factory amplifier and speakers.
- 2) Four channel line out converter for adding amplifiers to a standard factory speaker system.
- 3) Adding aftermarket amplifiers to a factory premium amplified system (Bose, JBL, etc.).
- 4) Installing a radio with floating ground speaker outputs to a common grounded speaker system like the early Fords.

The OEM-2 also includes a remote turn-on for amplifiers or a power antenna, providing 2 amps at 12 volts when 0.8 volts or greater is applied to the input side. This is useful for low voltage triggers like those used in Fords or for automatic triggering when audio is present. The output "turn on" is delayed 1 second to prevent turn on pops.

Input wiring colors		Output wiring colors	
White ¹	LF (+) speaker (high power)	White ⁶	LF (+) low level output
White/red ²	LF (+) speaker (low power)	White/red	LF (+) common gnd. speaker output
White/black ³	LF (-) common	White/black ⁷	LF (-) common
Gray ¹	RF (+) speaker (high power)	Gray ⁶	RF (+) low level output
Gray/red ²	RF (+) speaker (low power)	Gray/red	RF (+) common gnd. speaker output
Gray/black ³	RF (-) common	Gray/black ⁷	RF (-) common
Green ¹	LR (+) speaker (high power)	Green ⁶	LR (+) low level output
Green/red ²	LR (+) speaker (low power)	Green/red	LR (+) common gnd. speaker output
Green/black ³	LR (-) common	Green/black ⁷	LR (-) common
Violet ¹	RR (+) speaker (high power)	Violet ⁶	RR (+) low level output
Violet/red ²	RR (+) speaker (low power)	Violet/red	RR (+) common gnd. speaker output
Violet/black ³	RR (-) common	Violet/black ⁷	RR (-) common
Yellow ⁴	Constant battery	Yellow	Constant battery
Red ⁴	Switched power	Red	Switched power
Black ⁴	Gnd. neg. power	Black	Gnd. neg. power
Blue ⁴	Power antenna turn on	Blue	Power antenna turn on
Blue/white ⁵	Amplifier remote turn on 0.8 v min.	Blue/white	Amplifier remote turn on 2 amps max.
Orange ⁴	Illumination dimming	Orange	Illumination dimming

- ¹ Connect these wires to an aftermarket radio (+) high power speaker output (typically 20 watts x 4 and higher).
- ² Connect these wires to an aftermarket radio (+) low power speaker output. (All stereos up to 20 watts x 4 or when wiring for #4)
- ³ If the radio is high power (floating ground), connect these wires separately to each of the radio's speaker (-) wire (do not connect (-) speaker wires together). If the radio has a common ground speaker outputs, connect these wires together along with the radio's speaker ground.
- ⁴ These wires go directly through to the outputs for convenience of wiring. The red and black wires supply power to the internal low voltage trigger.
- ⁵ This wire needs only a minimum of 0.8 volts to supply 12 volts on the blue/white wire on the output side of the OEM-2.
- ⁶ For convenience, the positive leads of the RCA are connected internally to these wires.
- ⁷ For convenience, the grounds of the RCA are connected internally to these wires. Not used with common grounded speakers.

Note: Some Chrysler/Dodge vehicles with a Infinity premium sound system do not need any interface. If the speakers fade and balance correctly with this interface installed, but you have very little volume, then you do not need this interface.

1) Replace the factory premium radio with an after market radio/deck and retain the use of the factory amplifiers and speakers

Referring to the wire color chart above, connect the speaker outputs of the new radio to the OEM-2, using the positive, solid color, and the negative black-striped wires for all four channels. On the output side of the OEM-2 connect the solid color wires (+) and the black-striped wires (-) to the factory harness leading to the factory amplifiers. If there are common audio return wires (-) used in the vehicle for either the front and rear channels then connect the negative outputs of the OEM-2 to them. If there is only one audio return wire for all four channels connect all the black-striped wires to it. Connecting the constant power (yellow), switched power (red), ground (black), antenna trigger (blue), illumination (orange), and amplifier turn on (blue/white) through the OEM-2 simplifies wiring to the vehicle. The output level controls can be adjusted with a small screwdriver.

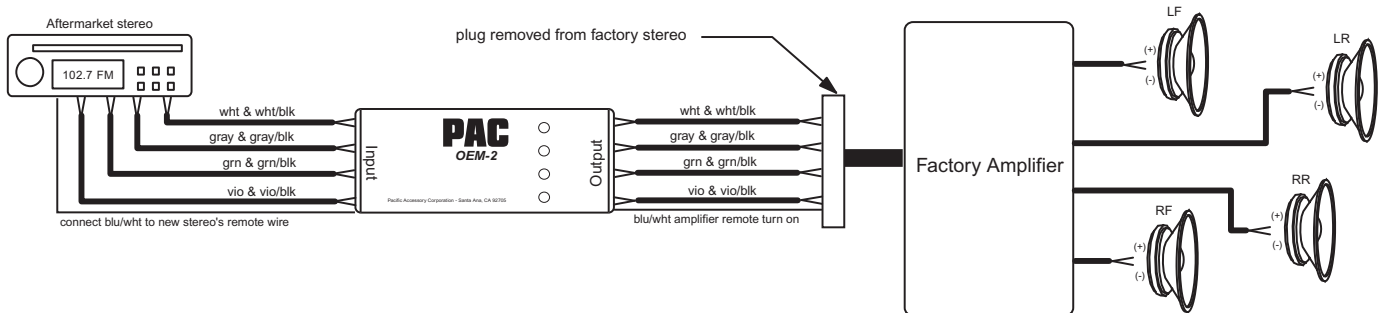

2) Adding an aftermarket amplifier to a standard factory radio that does not have factory amplifiers

The factory radio speaker outputs are connected to the OEM-2 inputs and the new amplifier is connected to the output side of the OEM-2, using the four RCA jacks and extension cables. Referring to the wire color chart, connect the factory radio speaker (+) outputs to the solid color wires and the (-) outputs to the black-striped wires. Example, LF speaker outputs of the factory radio connect to the white wire (+) and white/black (-). Continue for the remaining channels. The OEM-2 provides an amplifier turn on signal. To use, connect the blue/white wire on the OEM-2 input side to one of the positive speaker wires or to any source that provides 5 volts DC or greater. The blue/white wire on the output side will provide 12 volts to turn on the new amplifier. Connect the red (+) and black (-) wires on the input side to switched vehicle power and ground. Adjust the output level controls as needed using a small screwdriver.

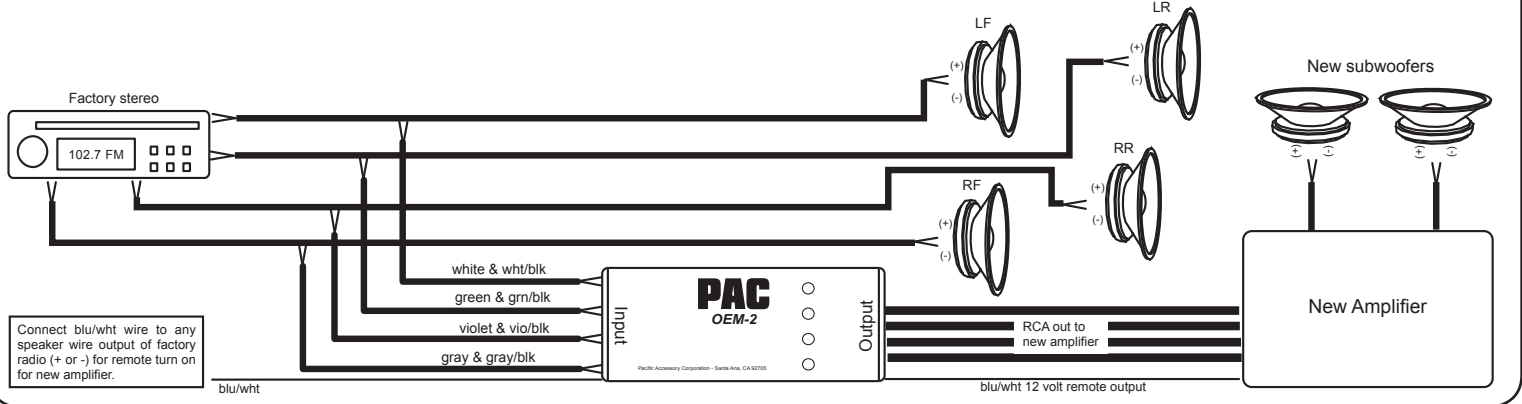

3) Adding after market amplifiers to a factory premium amplified system (Bose, JBL, etc.)

Referring to the wire color chart above, connect the audio output leads of the factory stereo to the input of the OEM-2, using the red striped wires as the positive input and black-striped as negative. Most premium systems use a low -level signal from the stereo to the factory amplifiers, therefore use the low level input of the OEM-2. Some factory-amplified systems use common audio returns and grounded shields like for instance, GM/Delco Bose vehicles. Do not cut the shield wire or attempt to use it as an audio signal wire. Determine if your system has two common audio return wires, one for the front channels and a second for the rear channels. If so, connect the negative input wires (black-stripe) for the front channels of the OEM-2 to the common audio return wire in the vehicle for the front channels. Do the same for the rear channels. If the vehicle has only one audio return wire for all channels connect all of the black striped wires to it. The output level controls can be adjusted with a small screwdriver. Connect the red (+) and black (-) wires on the input side to switched vehicle power and ground.

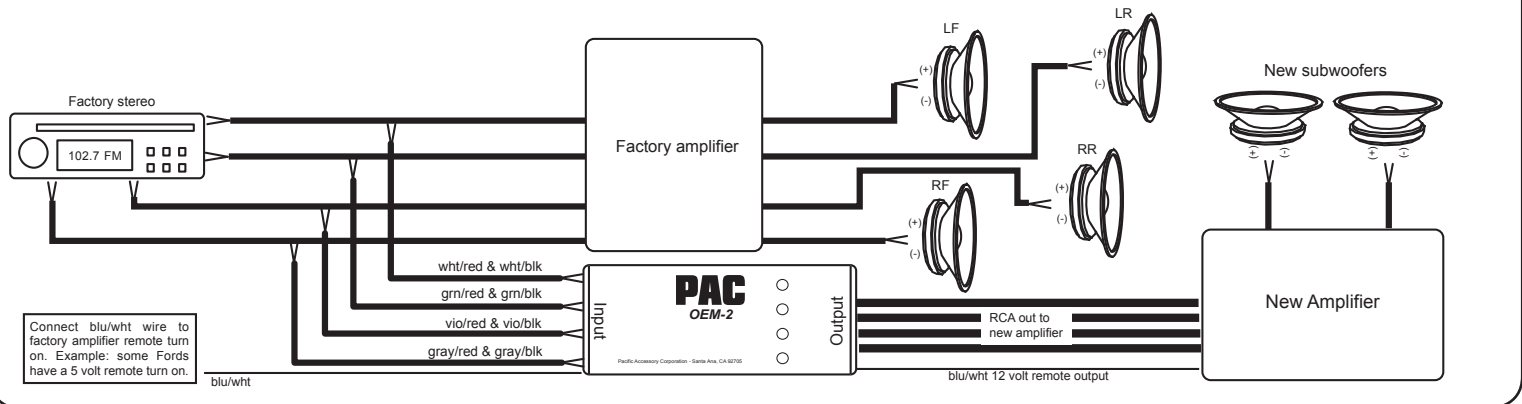

4) Installing a radio with floating ground speaker outputs to a common grounded speaker system like the early Fords.

Referring to the wire color chart, connect the new stereo positive speaker outputs to the red striped wire on the input side of the OEM-2. Connect the negative speaker outputs to the black-striped wires of the OEM-2. On the output side of the OEM-2 connect the red-striped wires to the vehicle positive speaker wiring. The black striped wires on the output are not used. The negative side of each speaker is either common to each other on one wire or two in the factory plug or already grounded to the chassis. However it may be, make sure that they are grounded to the vehicle chassis. The output level control on the OEM-2 will not function in this configuration.

